

PRODUCT CARD			
PRODUCT MODEL	MSBP0160A01HV1-TM1		
PRODUCT WEIGHT (Kg)			
DESCRIPTION	160A 01 UPS NONE ANALYZER INPUT-OUTPUT=3 POLE BY PASS=4 POLE		
FEATURES			
KEY TYPE	THERMAL MAGNETIC CIRCUIT BREAKER	UPS QUANTITY	1
POWER ANALYZER	NO	POWER LAMP.	YES
BRAND	CHINT		

**SINGLE LINE DRAWINGS**

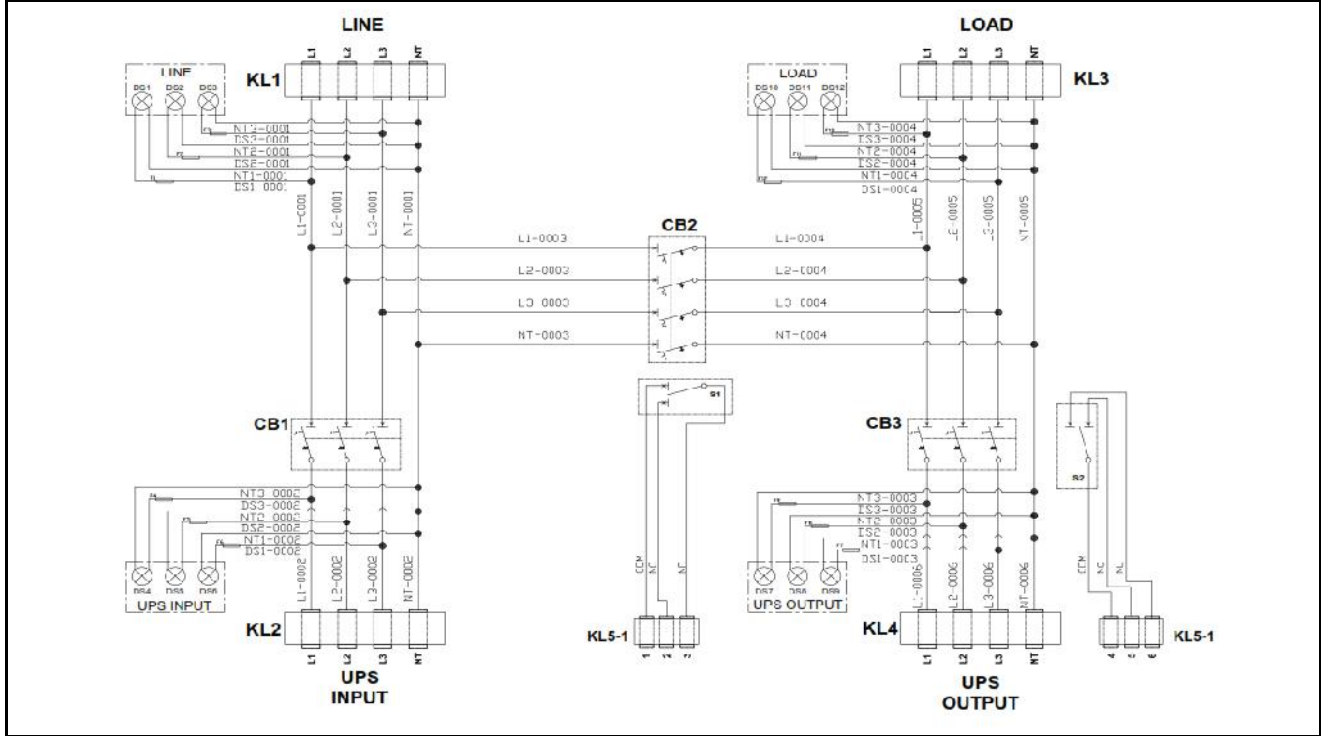

PANEL				
PANEL CODE	MKSBP0013	PANEL WEIGHT(Kg)		
SIZE(mm)(WxHxD)	500 x 800 x 200	ASSEMBLY SIZE(mm)(WxHxD)		568 x 845 x 223
USED RECORDS	PG 21	1 PIECE	PG 42	4 PIECE

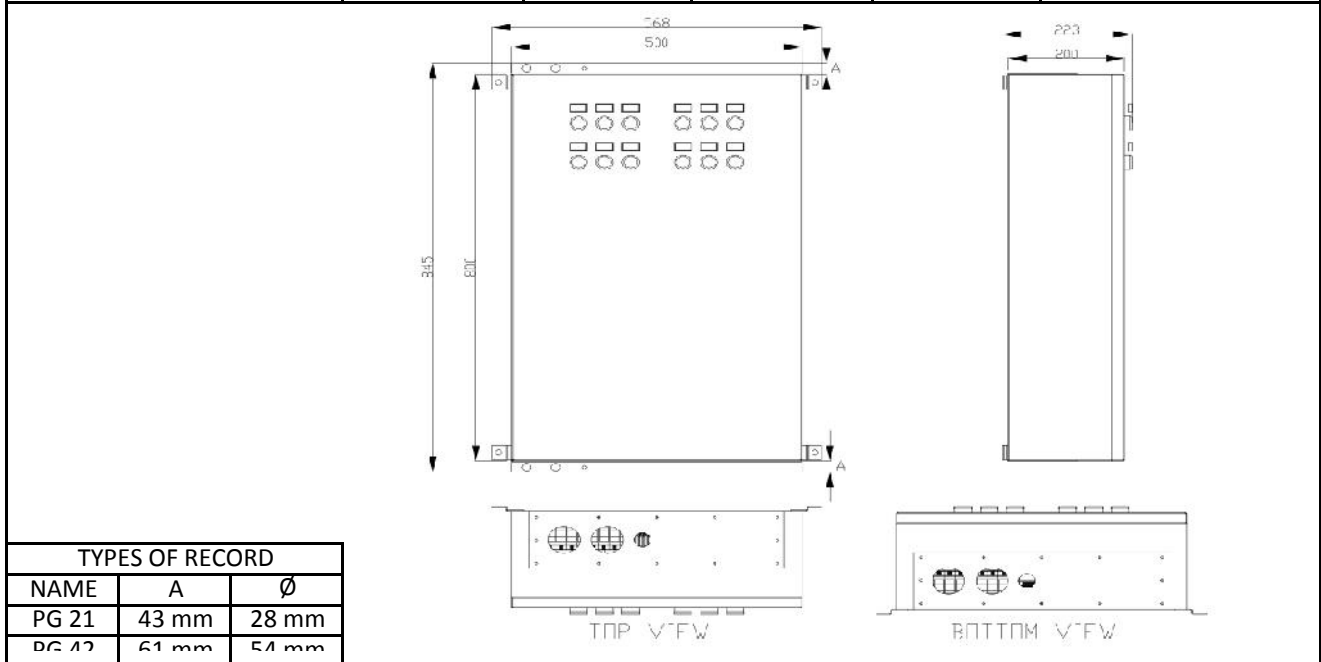

TYPES OF RECORD		
NAME	A	∅
PG 21	43 mm	28 mm
PG 42	61 mm	54 mm